

RECRUITER 2 QUICK-SHIP SETBACK WOOD SPORT LOCKER INSTALLATION INSTRUCTIONS

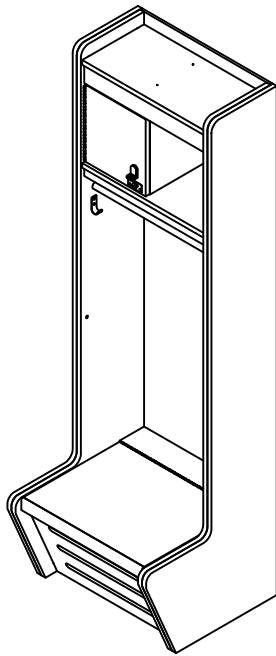

STARTER LOCKER

Includes 2 Finished End Panels (1 Left/1 Right)

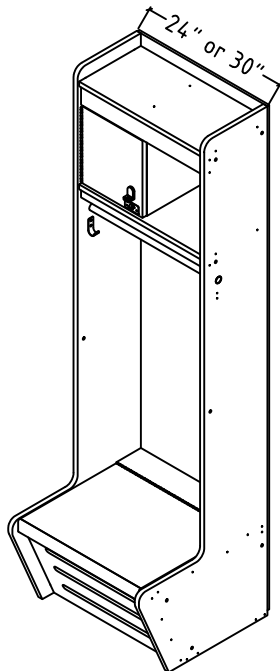

ADDER LOCKER

Outer sides Unfinished

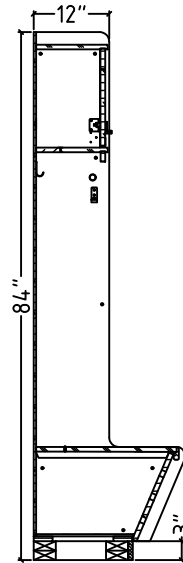

SIDE SECTION VIEW

General Instructions

1. Check material received against the packing list. First check the number of packages received and then check the contents of each package.
2. Check material received for damage. If damage has occurred, secure a "damage notation" from the carrier.

CAUTION

IN THE INTEREST OF SAFETY, ALL LOCKERS MUST BE SECURELY ANCHORED TO THE FLOOR AND/OR WALL.
FOR SAFETY, HANDLE ALL COMPONENTS CAREFULLY AND WEAR WORK-GLOVES WHEN INSTALLING LOCKERS.
INSTALL ALL UNITS LEVEL AND PLUMB, AND TIGHTEN ALL HARDWARE SECURELY.
RETAIN INSTRUCTIONS FOR FUTURE REFERENCE.



401 Jim Moran Blvd., P.O. Box 4157 Phone (954) 429-9662
Deerfield Beach, FL 33442 Fax (954) 428-3843

www.ListIndustries.com

RECRUITER 2 QUICK-SHIP SETBACK WOOD SPORT LOCKER INSTALLATION INSTRUCTIONS

1. Install wood sleepers (by others), (see DETAIL A). Note that a level sleeper base is critical for a quality locker installation, shim as needed. Pressure treated 2" x 4" at floor. Standard 2" x 4" at second level.
2. For lockers that are to be installed wall to wall wood sleeper base run should be $\frac{3}{4}$ " from wall. For lockers not installed against wall, sleeper base should stop at the last locker in run.
3. If locker electrical component options are selected, electrical connection must be provided by a licensed electrician. Electrical connection wiring should be done before lockers are anchored. A certified electrician must wire the lockers through back panel cutout, please see DETAIL B.
4. If applicable, install finished end panel prior to placing first locker.
5. Remove white nail-on glide from base (bottom) of locker before anchoring to sleeper base.
6. Fasten each adjacent locker using joint connector bolt and nut at locations shown in DETAIL C. End panels use same locations for fastening.
7. Attach lockers to wall, inside every second security box to conceal fastener. Shim as needed.
8. Anchor every locker to sleeper base using furnished #8 x 2-1/2" wood screws. Shim as needed, see DETAIL A.



401 Jim Moran Blvd., P.O. Box 4157 Phone (954) 429-9662
Deerfield Beach, FL 33442 Fax (954) 428-3843

www.ListIndustries.com

RECRUITER 2 QUICK-SHIP SETBACK WOOD SPORT LOCKER INSTALLATION INSTRUCTIONS

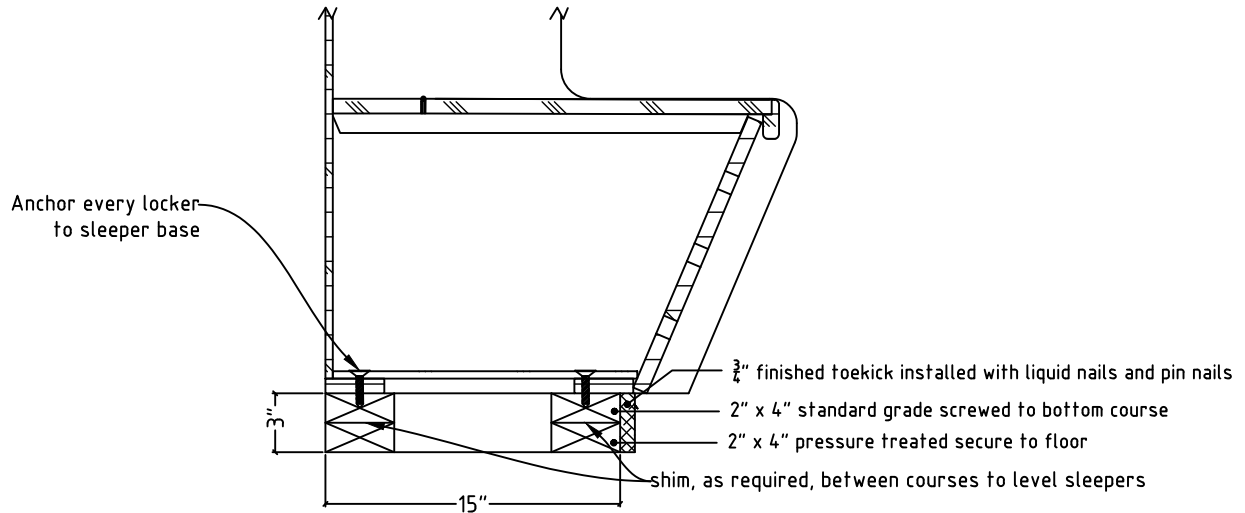

DETAIL A: Sleeper Layout (Section View)

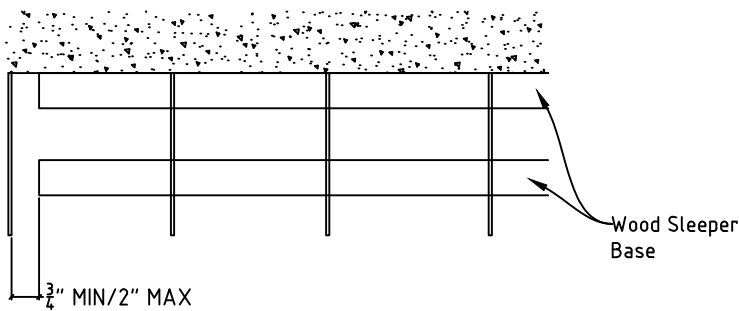

Sleeper Base Top View

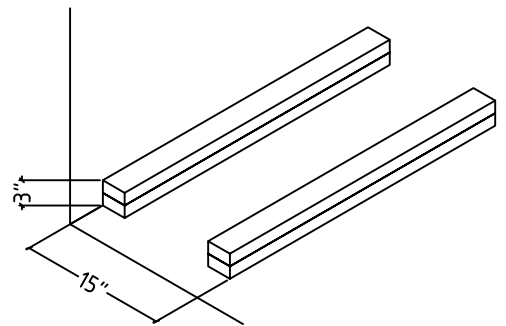

Sleeper Base Detail



401 Jim Moran Blvd., P.O. Box 4157
Deerfield Beach, FL 33442

Phone (954) 429-9662
Fax (954) 428-3843

RECRUITER 2 QUICK-SHIP SETBACK WOOD SPORT LOCKER INSTALLATION INSTRUCTIONS

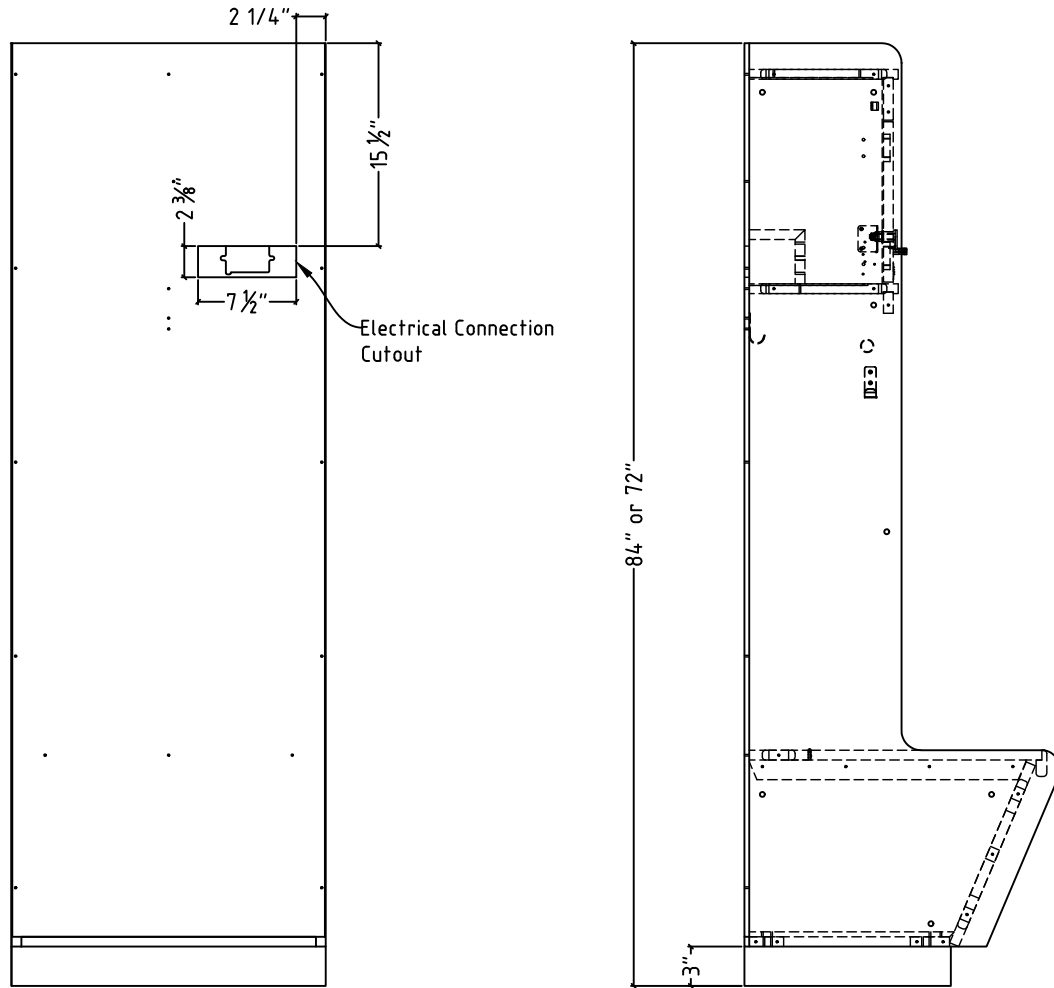

DETAIL B: Recruiter Locker USB Cutout Detail



401 Jim Moran Blvd., P.O. Box 4157 Phone (954) 429-9662
Deerfield Beach, FL 33442 Fax (954) 428-3843

www.ListIndustries.com

RECRUITER 2 QUICK-SHIP SETBACK WOOD SPORT LOCKER INSTALLATION INSTRUCTIONS

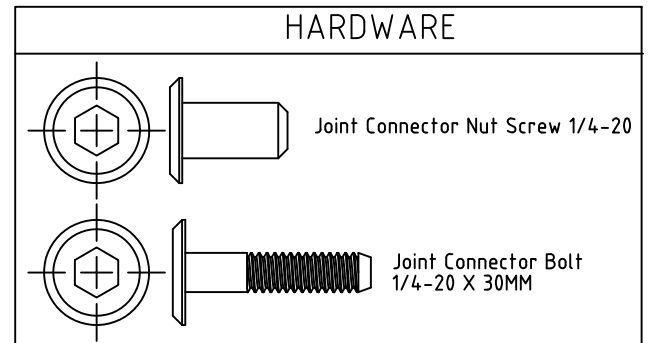
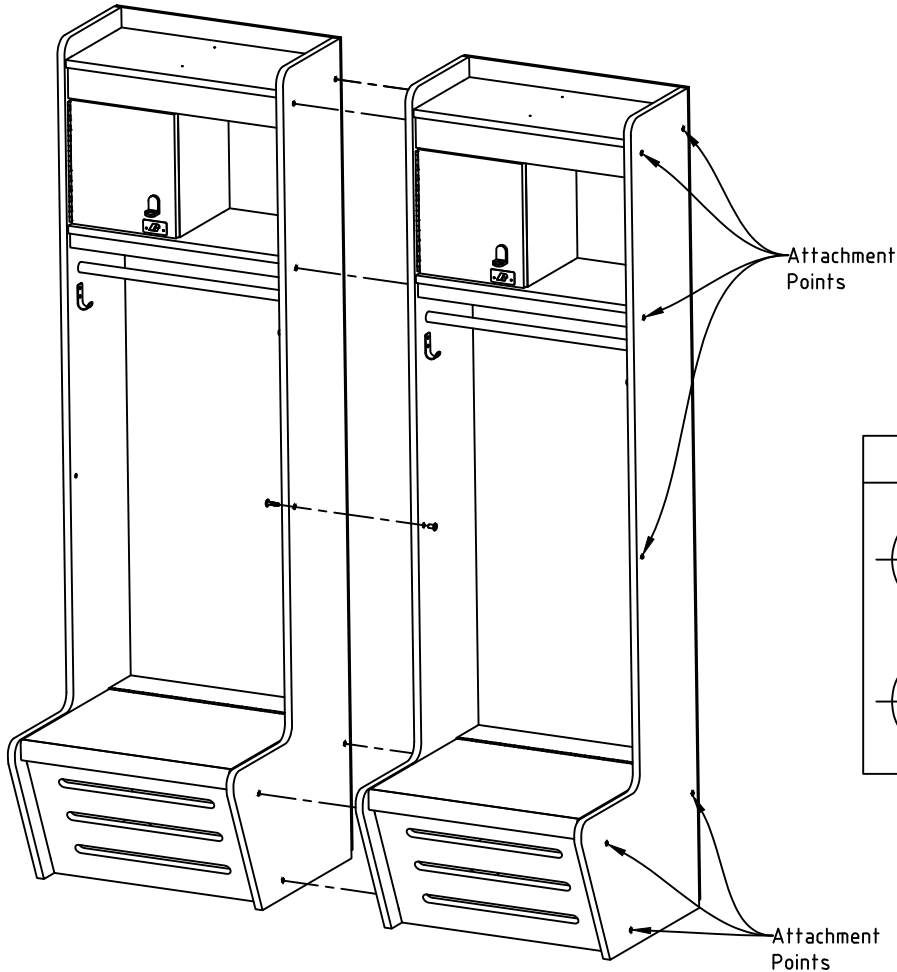

DETAIL C: Adjacent Locker Attachment Points

Ensure front of lockers are flush before tightening



401 Jim Moran Blvd., P.O. Box 4157
Deerfield Beach, FL 33442

Phone (954) 429-9662
Fax (954) 428-3843

www.ListIndustries.com

RECRUITER 2 END PANEL INSTALLATION INSTRUCTIONS

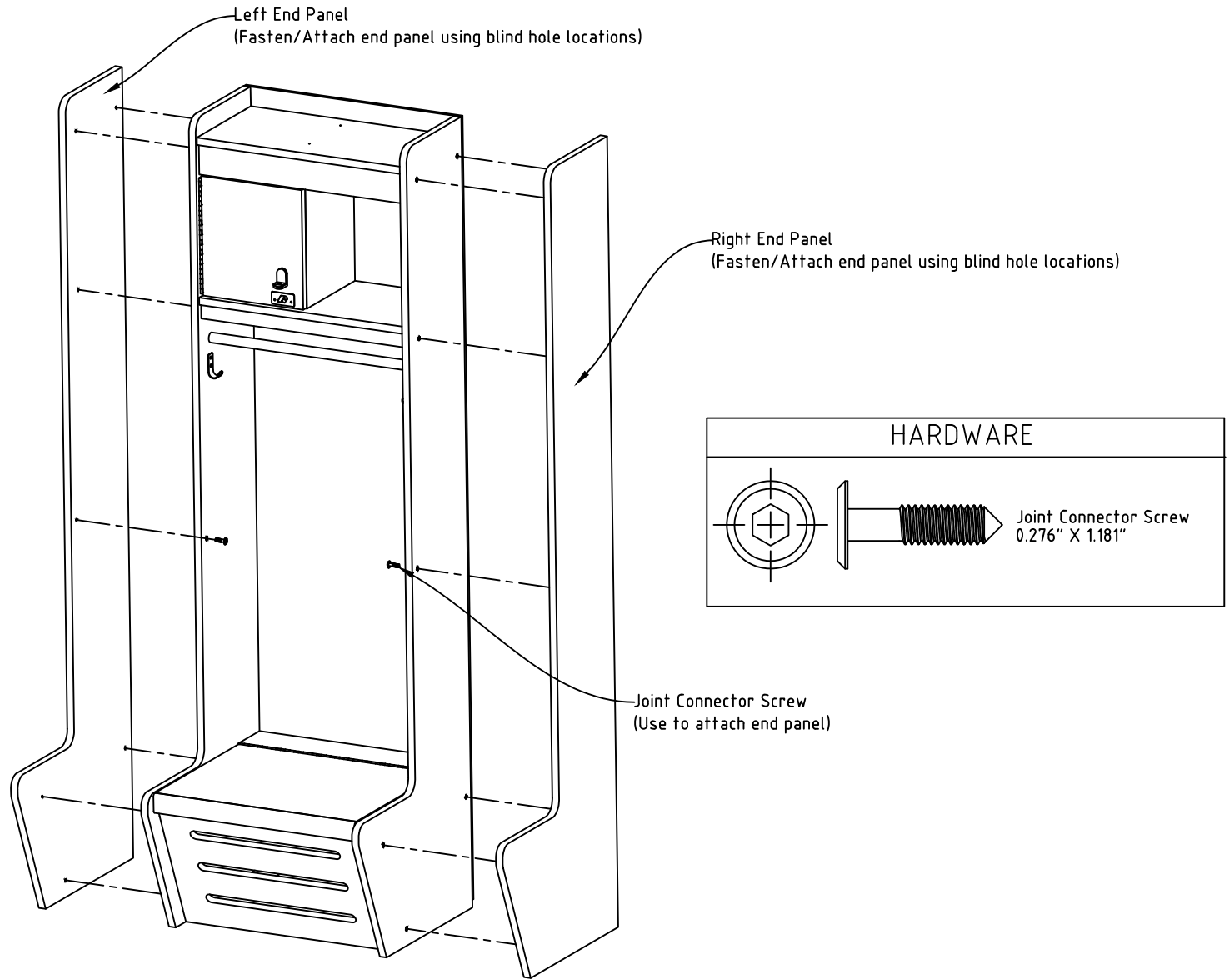

FINISHED END PANELS
For exposed ends only



401 Jim Moran Blvd., P.O. Box 4157
Deerfield Beach, FL 33442

Phone (954) 429-9662
Fax (954) 428-3843

RECRUITER II ACCESSORY INSTALLATION INSTRUCTIONS

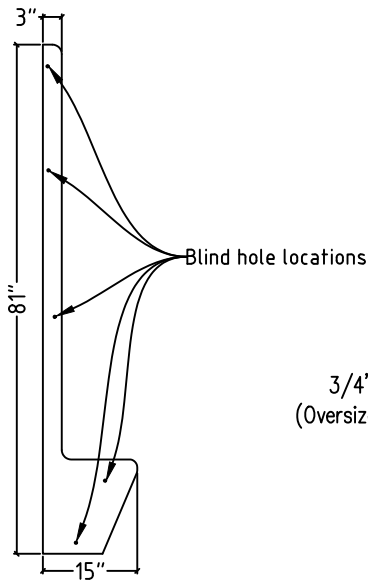

PARTIAL FINISHED END PANEL
(Used only on Corner Fillers and Front Fillers)

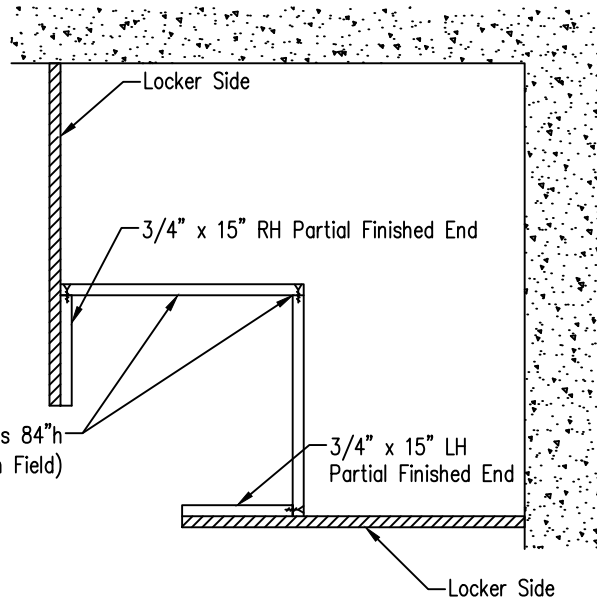

CORNER FILLER DETAIL

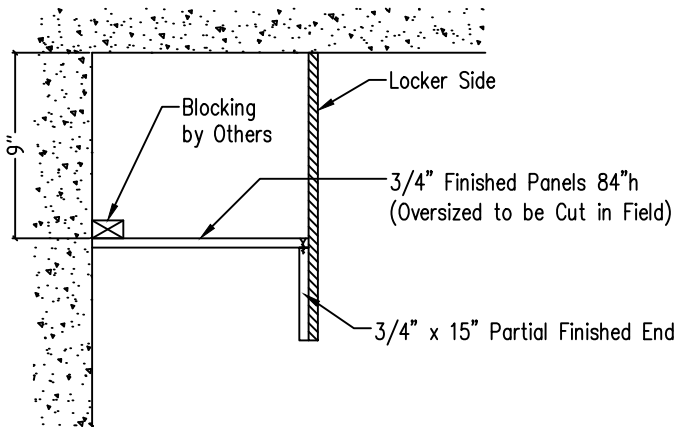

FRONT END FILLER DETAIL
(LH Shown)

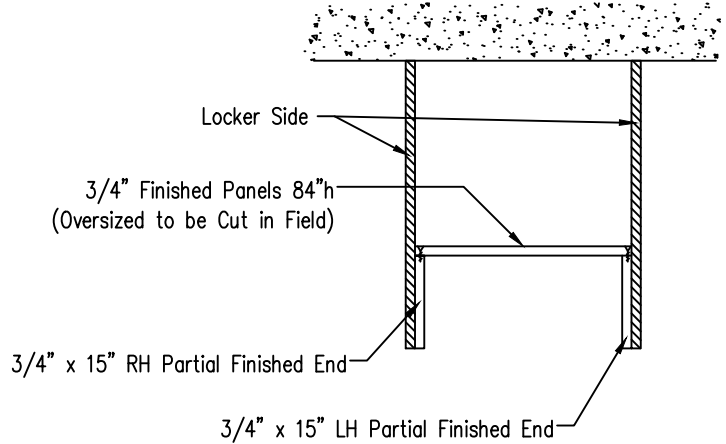

FRONT INTERMEDIATE FILLER DETAIL



401 Jim Moran Blvd., P.O. Box 4157
Deerfield Beach, FL 33442

Phone (954) 429-9662
Fax (954) 428-3843

www.ListIndustries.com

RECRUITER II ACCESSORY INSTALLATION INSTRUCTIONS

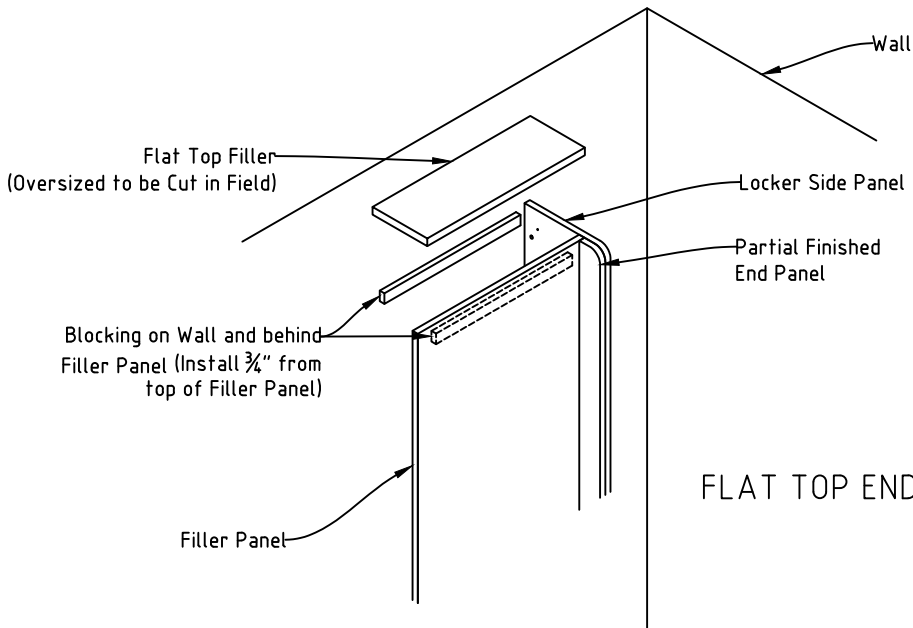

FLAT TOP END FILLER DETAIL

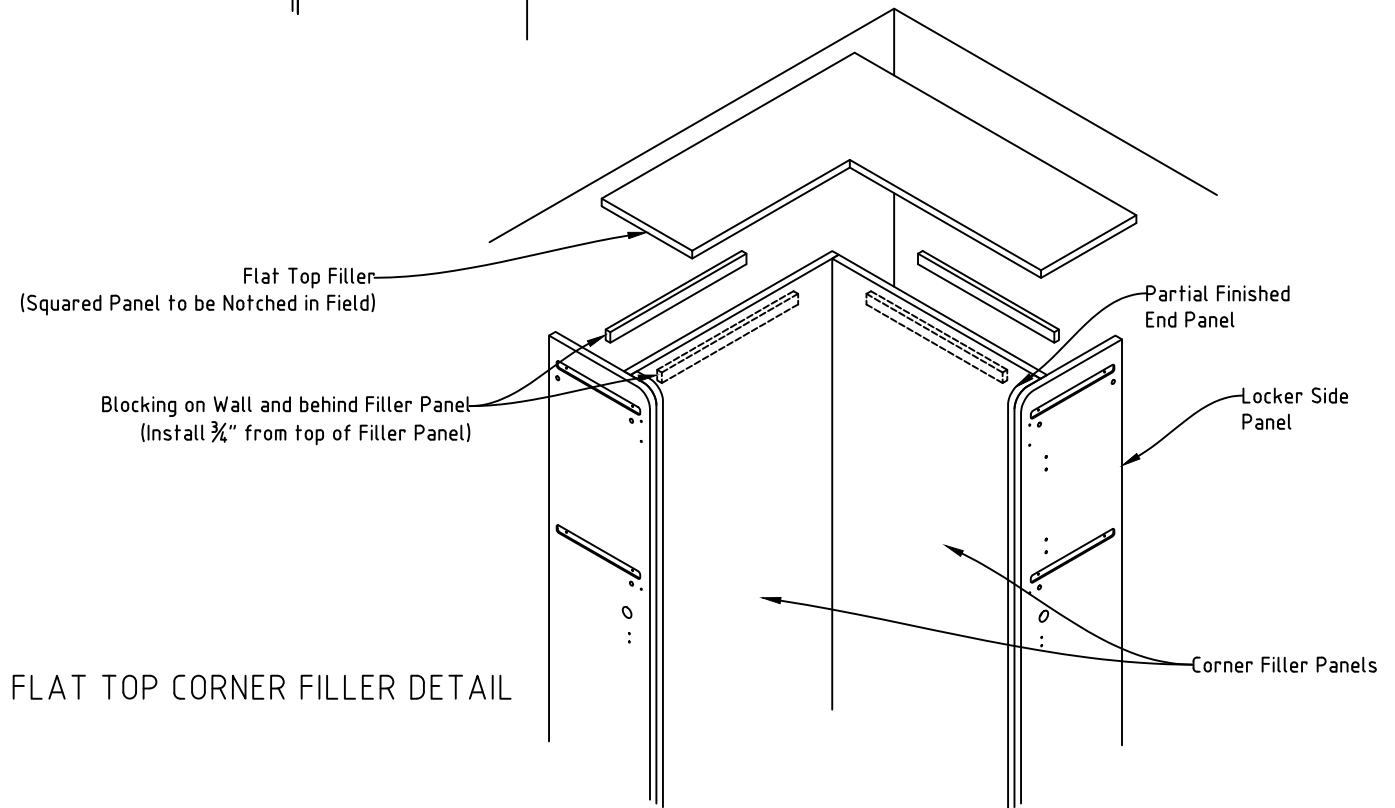

FLAT TOP CORNER FILLER DETAIL



401 Jim Moran Blvd., P.O. Box 4157
Deerfield Beach, FL 33442

Phone (954) 429-9662
Fax (954) 428-3843

www.ListIndustries.com