

6" HIGH CLOSED FRONT & SIDE BASE

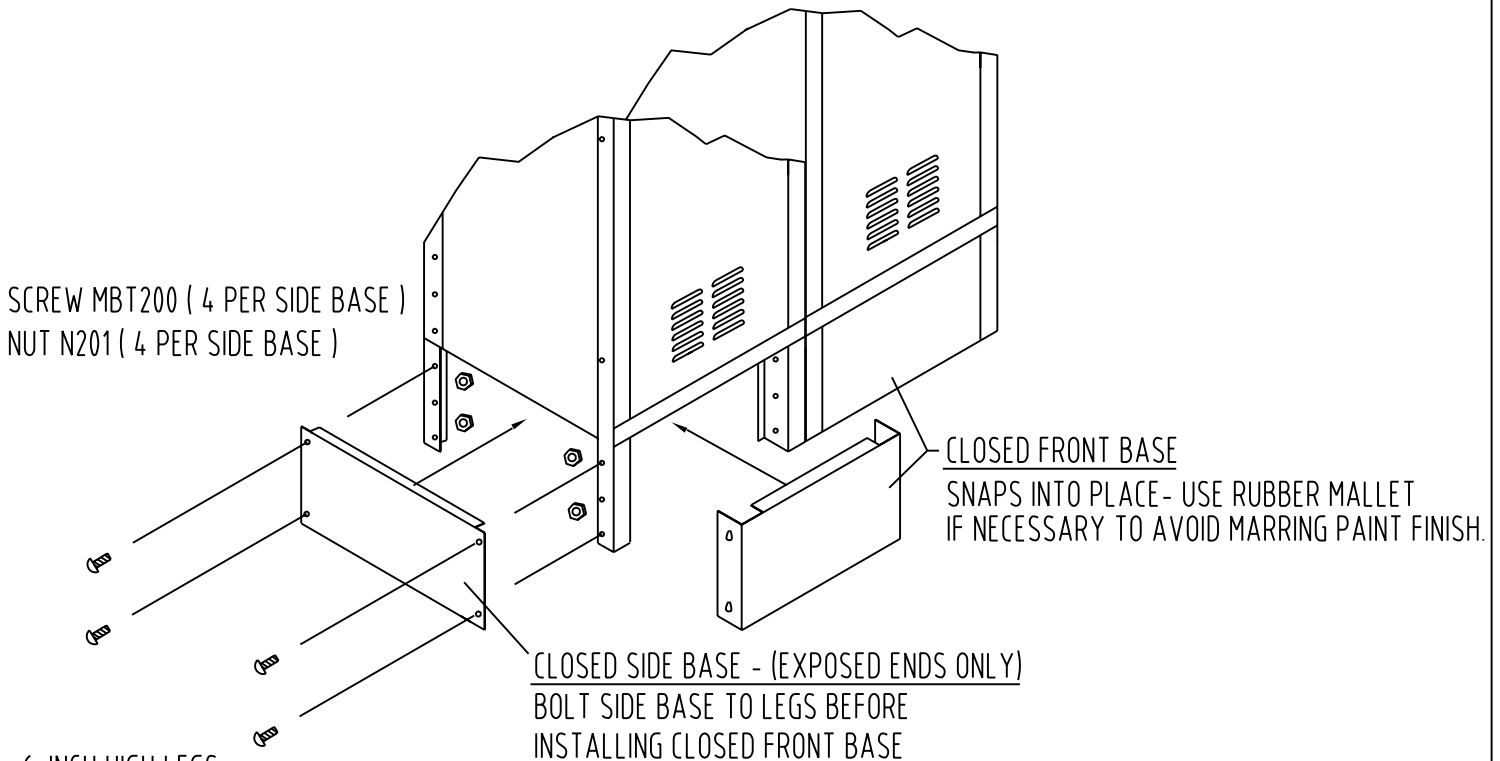

6-INCH HIGH LEGS:

LEGS ARE STANDARD AND ARE INTEGRAL WITH FRAME UPRIGHTS IN FRONT
REAR LEGS ARE BOLTED TO SIDE AND BACK
(USE TWO REAR LEGS FOR 1-WIDE AND 3-WIDE UNITS).

6-INCH HIGH LEGS WITH CLOSED METAL BASE:

CLOSED FRONT AND SIDE BASE ARE OPTIONAL.

General Instructions

1. Check material received against the packing list. First check the number of packages received and then check the contents of each package.
2. Check material received for damage. If damage has occurred, secure a "damage notation" from the carrier.
3. Identify each part as it is unpacked and put like parts together as close as possible to the working area in which they are to be assembled.
4. Be careful to use the correct hardware as specified in the assembly instructions.

CAUTION

IN THE INTEREST OF SAFETY, ALL LOCKERS MUST BE SECURELY ANCHORED TO THE FLOOR AND/OR WALL.
FOR SAFETY, HANDLE ALL COMPONENTS CAREFULLY AND WEAR WORK-GLOVES WHEN ASSEMBLING LOCKERS.
INSTALL ALL UNITS PLUMB AND TIGHTEN ALL HARDWARE SECURELY.

RETAIN INSTRUCTIONS FOR FUTURE REFERENCE.



401 Jim Moran Blvd., P.O. Box 4157
Deerfield Beach, FL 33442

Phone (954) 429-9662
Fax (954) 428-3843

www.ArtMetalProducts.com